

Technical Rider

Nivis

(as of May 2023)

Tel. : +49 179 976 40 36 (Johannes Dorsch)
Tel. tech: +49 170 936 28 60 (Andy Schindler)
Email: hello@nivis-music.com
Web: www.nivis-music.com

General

- Hello! We are Nivis. We are five people, we travel by car and need parking near the venue
- Setting up our equipment and line check will take about 25 min.
- Stage dimensions: min. 5m x 2,5m
- Solid PA system with powerful bass

Mixer

- 18 channels, 3 AUX (pre) optional
- We need a sound engineer to mix us

Monitors

- We bring our own in-ear monitoring system, wich works independently from the venues mixing console
- Stage monitors (wedges) are optional and would only be a backup

Licht / Visuals

- We require
 - either subtle stage lighting
 - or a lighting technician, who adapts our cue list
- If available: canvas and a beamer or a screen with HDMI
Else: a way to mount our backdrop (ca.4x3m)

Merchandise

- We have some merch to sell (shirts, hoodies, bags)
- We would be very grateful if you could provide a table to place our merch

Backstage

- Water, soda, beer, Jameson Whiskey
- Food for 5 people (4 vegetarians), allergies: kiwi

THANK YOU!

Stage Plan & Input List for Nivis

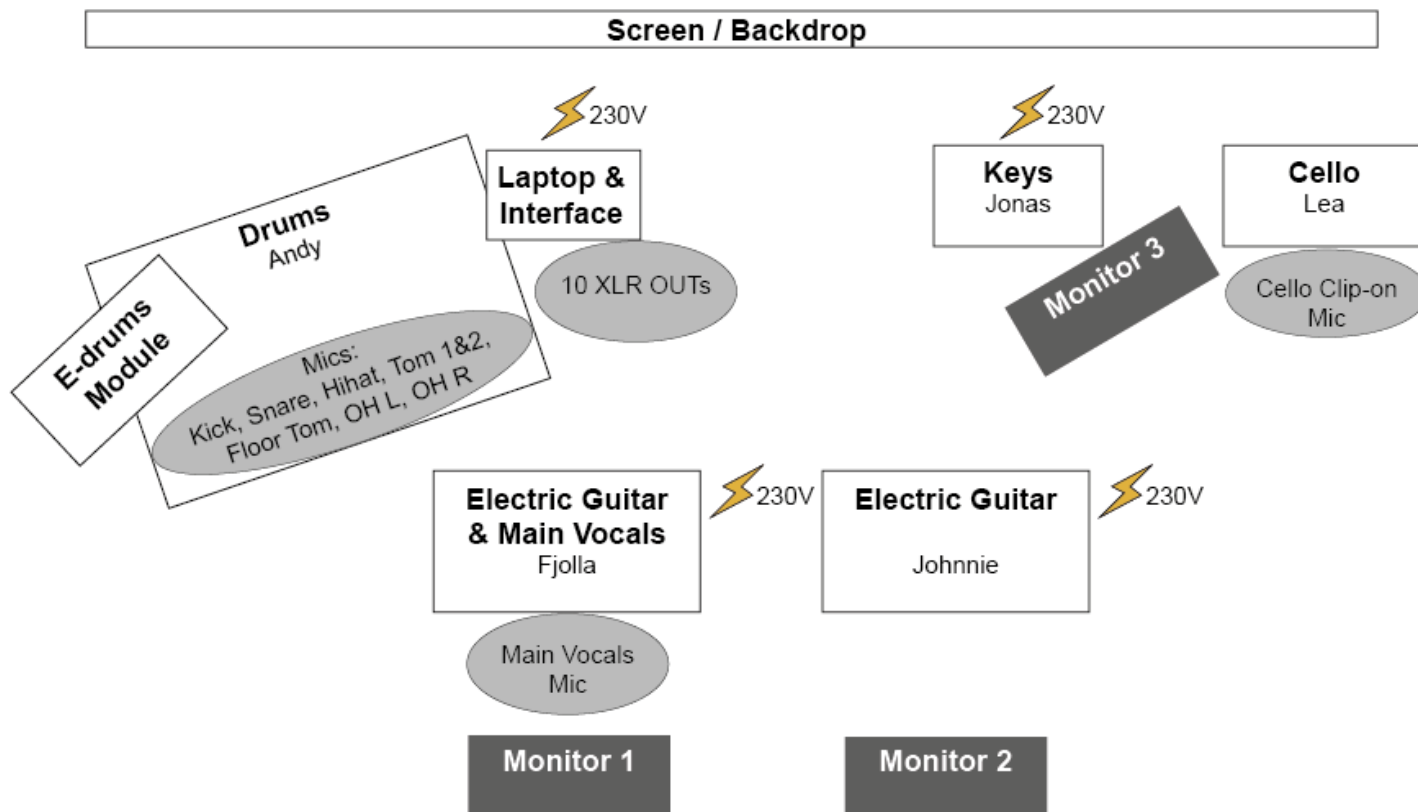

✓ means: we carry this

DI means: signal comes from our interface (via balanced XLR, through an isolator)

CH	Instrument	Played by	Mic/Line/DI	Phantom	Stand
1	Kick	Andy	D112, Beta52A or similar		small
2	Snare	"	SM57 or similar		small
3	Hihat	"	SM81, e914 or similar	+48V	small
4	Tom 1	"	SM57, MD421 or similar		medium
5	Tom 2	"	SM57, MD421 or similar		medium
6	Floor Tom	"	SM57, MD421 or similar		small
7	Overhead L	"	C414, e914 or similar	+48V	boom
8	Overhead R	"	C414, e914 or similar	+48V	boom
9	E-drums	"	DI		
10	Bass	Interface	DI		
11	E-Git Johnnie L	Johnnie	DI		
12	E-Git Johnnie R	Johnnie	DI		
13	E-Git Fjolla	Fjolla	DI		
14	Main Vocals	Fjolla	Audix OM6 ✓ via DI		Standard ✓
15	Keys	Jonas	DI		
16	Cello	Lea	AT C519 ✓ via DI		
17	Misc* L	Interface	DI		
18	Misc* R	Interface	DI		

*Misc = additional keys, pads, backings, FX from our playback